

719

Trifaze Sayaç Okuma Camı / Counter Screen

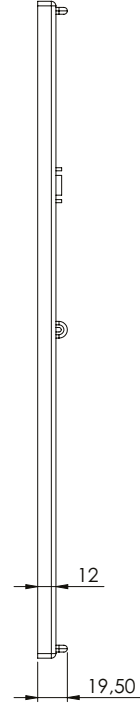
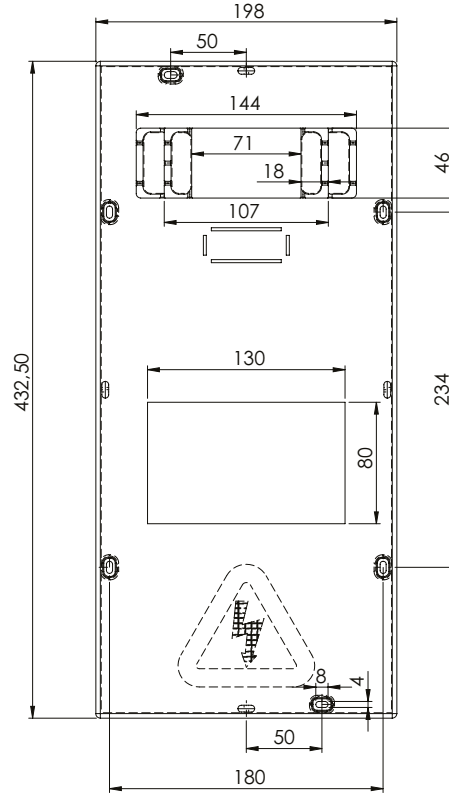

719-2

Monofaze Sayaç Okuma Camı / Counter Screen

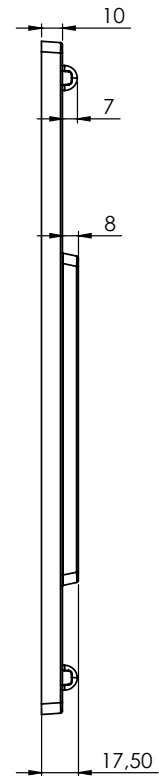
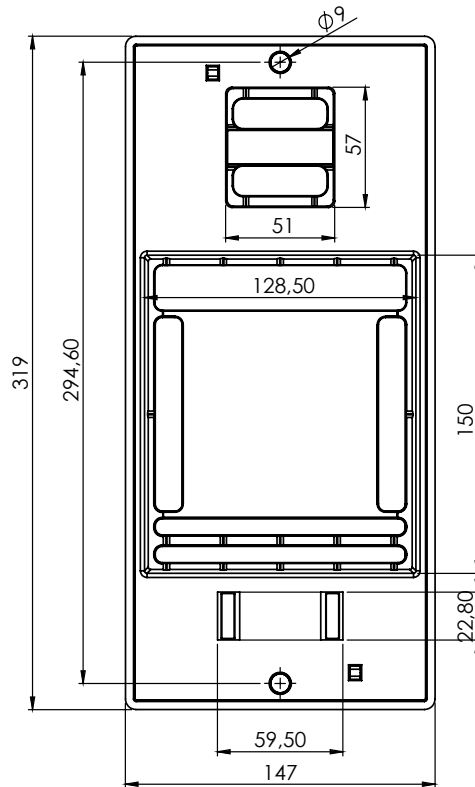
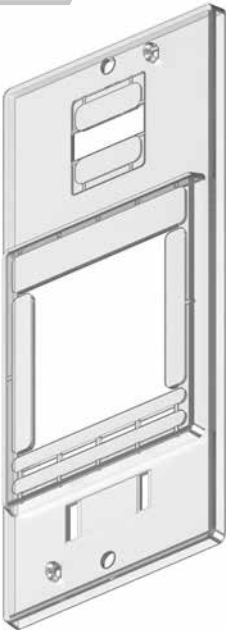

KULLANIM ALANLARI:

Elektrik Panoları

APPLICATIONS:

Electric Panels

MALZEME / MATERIAL

GÖVDE
BODY Polikarbonat veya Kristal
Polycarbonat or Crystal